

SkyWalk™ S50R

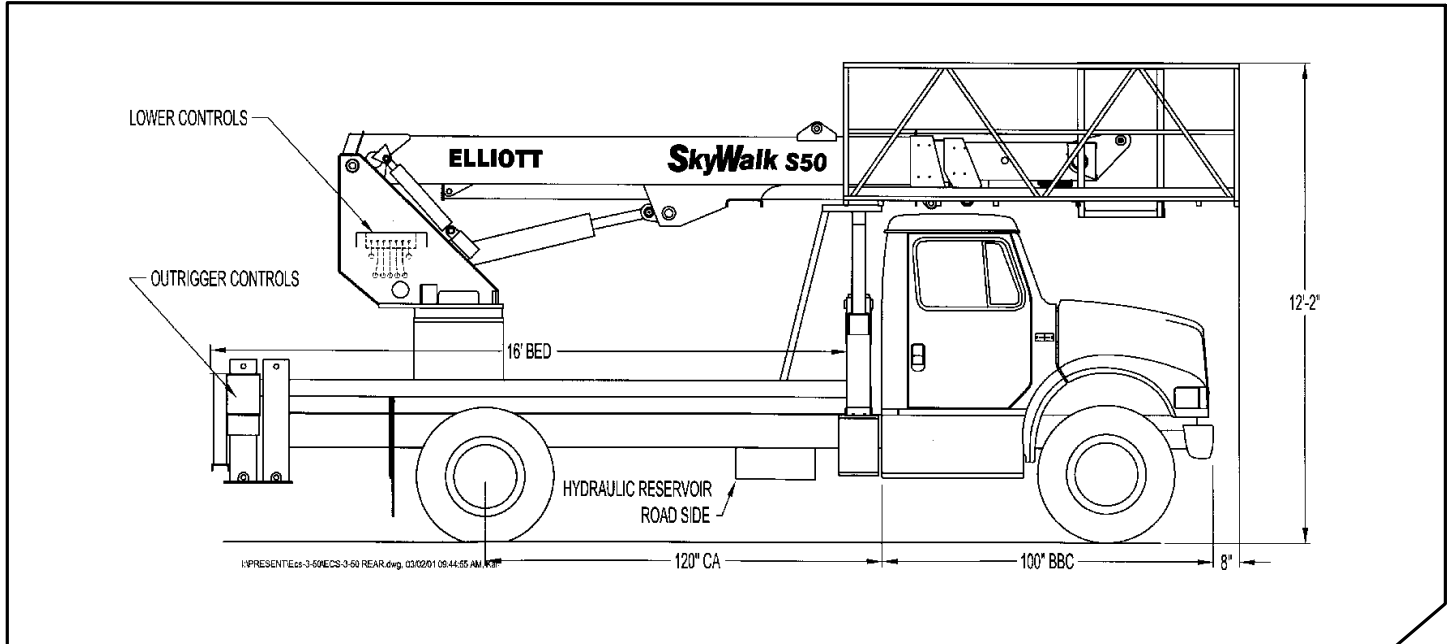

GENERAL UNIT DESCRIPTION

SkyWalk™ Do more work, for more years with a single machine—the Elliott SkyWalk. This multi-use machine features a unique, oversized platform that carries three full-sized men, along with their tools. Always ready for heavy duty, the SkyWalk's full-feathering proportional controls also make it deftly maneuverable. In fact, you can more precisely place your workers to increase your accessible work area, while you cut repositioning time too. Only Elliott features full hydraulic extension with no cables and chains. Our extension cylinder arrangement gives you the smoothest, most precise ride in the industry. In fact, when you add up the numbers—900 lbs. of capacity, 350-degree workplatform rotation and 16 feet of deck space. Nothing adds to your fleet like the SkyWalk.

Basic unit includes base assembly supporting front mounted rotating turret, hydraulically powered continuous rotation mechanism, oil reservoir mounted to truck frame, oil, and manual hydraulic controls mounted to turret. Electronic proportional four stick remote controls on platform. Base mounted "MH" type hydraulically powered individually controlled main outriggers. Underslung "A" type outriggers for rear stabilization. Front bumper stabilizer. High strength steel three section hydraulically telescoping boom with one double acting 6-1/2" lift cylinder. One exposed cable carrier to boom tip. Hydraulically self-leveling top mount 28" wide x 16 ft. long work platform with 350 degrees hydraulic rotations and remote leveling from platform. Power take off and pump drive, pressure gauge, pump and holding valves on all cylinders. Remote start/stop at upper and lower controls, 12-volt emergency pump with switch at upper and lower controls, PTO hour meter, backup alarm, fire extinguisher, and two body harnesses and lanyards. Paint Hi-Reach white, outriggers red and bed and boxes black. Installed on chassis, tested and ready to operate. Working height 55'. Platform capacity 900 lbs.

Technical Specifications

Minimum Platform Height: 50' ground to platform floor.

Working Range: 55' max. height and 52' max. side reach.

Work Platform: 28" x 16 feet work platform with 42" high rails. Equipped with two safety lanyard attachment loops and two safety harnesses with lanyards. Platform capacity 900 Lbs.

Platform Leveling System: Hydraulic "closed" system consisting of a platform cylinder interacting with a boom-actuated master cylinder mounted in boom support turret. System provided with factory-set relief valves to compensate for oil expansion or overload during platform leveling operation. Remote releveling controls provided in platform and at ground controls to give precise releveling capability.

Platform Controls: Four individual proportional electronic controllers meter pilot-operated, pressure-compensated modulating valves for boom controls and platform rotation. Remote controls for boom operations from platform operate from a removable remote control box. Hi/Lo range, start/stop and engine speed toggle controls are also located at platform. Electric remote control cable extends through the electrical slip ring to cable carrier on side of boom to extending boom sections.

Lower Controls: Mounted on curbside of turret.

Outrigger Controls: Parallel open-center stack valve for lever-operated control of right and left outriggers. The main and secondary outrigger valves are mounted at the rear, under each corner of the bed with roadside valve controlling roadside outriggers and curbside valve controlling curbside outriggers. Front bumper jack controlled with single valve at front bumper.

Outriggers: "MH" out-and-down main outriggers with 18 ft. spread. Additional stabilization provided by underslung rear outriggers and one tilting front bumper jack.

Frame: One piece, all welded, box-type fabrication with integral outrigger mounts. Bolt-on torque frame distributes load to front of truck.

Turret: Reverse offset turret is one-piece weldment. Turret rotates on large diameter ball bearing.

Rotation: Continuous turret rotation with no stops. Hydraulic motor drives turret through self-locking gear box.

Boom: Three high strength, plated rectangular tube sections. Assembly includes heavy-duty cylinder fittings, pivot pins, replaceable boom roller bearings, and replaceable wear pads.

Boom Extension: A two-stage double acting cylinder, with cylinder pins connecting the three boom sections.

Lift: One double-acting 6-1/2" full displacement, long stroke cylinders provide smooth and stable boom elevation. Holding valve prevent boom from falling in event of hose failure.

Cylinders: All cylinders use microhoned cylinder tubing, chrome shafts, top grade packing and protective rod wipers. Cylinder-mounted holding valves provided on all load-holding cylinders.

Hoses: All high pressure hose is wire braid reinforced with a minimum safety factor of 4 to 1.

Oil Tank Capacity: 70 gallon mounted to truck frame on roadside.

Hydraulic System: Operating pressure approximately 2,500 PSI. System is parallel open center type and is equipped with liquid-filled pressure gauge. Oil is supplied to upper cylinders through hydraulic union in center of turret to cable carrier along side of the boom.

Pump: Gear type, direct mount to truck PTO. 14 GPM @ 2,500 PSI on high engine speed.

PTO: Heavy-duty, high-speed. Cable engaged from cab.

Cab Equipment: PTO cable with indicator lights installed in truck cab. Engine speed control and start/kill installed with control switches in platform remote control box and also located at lower controls. U/L approved 5:BC dry chemical fire extinguisher installed in truck cab.

Operators Manual & Video: Two copies of operation, maintenance, safety and parts manual provided with each unit. Operational and safety video provided at delivery.

Installation: Unit installed on customer's truck, painted, system and tank filled with oil, tested, inspected, certified and ready to operate.

Standard Paint: Paint Hi-Reach white, outriggers red, and bed and boxes black. Top of bed painted with black nonskid surface.

Bumper: Bureau of Motor Carrier Safety rear bumper.

Weight: Approximately 15,500 lbs. with 22' steel-floor bed less truck.

Truck Chassis Required: Approx. 156" C.A. RBM 1,600,000 in-lb. per rail, 12,000 lb. front axle and 33,000 lb. GVWR required. Trucks must have extended rear frame, increased cooling, heavy-duty front and rear springs, 12V electrical system with high capacity alternator, cab clearance stop/tail/backup lights, and I.D. lamps. Additional equipment to consider: front tow hook, pintle hook, mud and snow tires for off highway use. Recommended GVWR is minimum for HI-REACH with flatbed only. Contact factory when additional equipment is to be added.

Options

Bed: Length 22' (other lengths available) Width 98" with 3/16" steel tread plate floor, 6" rub rail and heavy duty cross members. Stake pockets on both sides of bed. Spray suppressant splash guard installed. Chassis stop/turn/back-up lights remounted as necessary. Rear clearance and side market lights with reflectors on bed.

Heavy-Duty Hydraulic Winch: Mounted to the boom for a long fleet angle and flat level spooling of cable. Heavy-duty winch supplied with 180 ft. of 3/8" diameter 6x37 IPS IWRC wire rope and swivel hook. Anti-2-block switch, 2-part hook, horn and certification to ANSI B 30.5 mobile cranes provided.

12 ft. long platform

Platform Jib

Hydraulic, Air & 110V Lines to Platform

Welder Generators

Wood-Floor Bed

Line Bodies

Tool Storage

Full Cab Guard

Miscellaneous Options...Contact factory for details



4427 South 76th Circle

Omaha, NE 68127

Phone: 402-592-4500

Fax: 402-592-4553

Email: info@elliottequip.com

www.elliottequip.com

